

Lambda/175

Shower trolley/changing table

Primary application

Home care
Institutional
Hospital

Lambda's clean look and supreme functionality exemplify innovative Scandinavian design at its best, making Lambda the ideal choice for home care and institutional use.

Lambda's many features like its class leading lifting range, the standard tilt function and adjustable side rails, make for an optimum showering aid, providing comfort and safety for the user. And all at the push of a button on the hand control.

Additional features include drainage channels on the mattress to ensure the user is not left in a pool of water before transfer, thereby enhancing both safety and comfort in a bathing situation.

Paired braking and directional locking wheels ensure ease and safety of use.

Key standard functions

Powered height adjustment via hand control
Powered tilt facility (Anti-Trendelenberg)
Adjustable side, foot and head rails
Central braking on paired wheels

Accessories

Charger
Additional battery
Neck cushion
Remote battery charger



PRODUCT HIGHLIGHTS

- Class leading, high-low lifting range.
- Anti-trendelenberg (tilt facility) up to 10 degrees.
- Adjustable side, head and foot rails.
- Central braking and directional locking.
- Maintenance free, large low friction castors, smooth rolling for easy manoeuvrability.
- Height and tilt functions powered via hand control unit.



Paired braking and directional locking on low friction wheels.



High capacity battery.



Tilt feature for comfort, positioning and drainage.



Functional hand control

Version	Item-number
Lambda with mattress	012-00002
Accessories	
Charger	253-00201
Additional battery	250-01212
Neck support	012-00005
Remote battery charger	017-00200

TECHNICAL SPECIFICATION

Max. load	385 lbs
Total weight	254 lbs
Lifting interval	23.5" / 41.5"
Length	80.6"
Width	30.3"
Anti Trendelenburg angle	approx. 10 degrees
Height adjustment	battery powered
Power supply	24V Linak system
Wheel diameter	5.9"
Material	Powder coated stainless steel

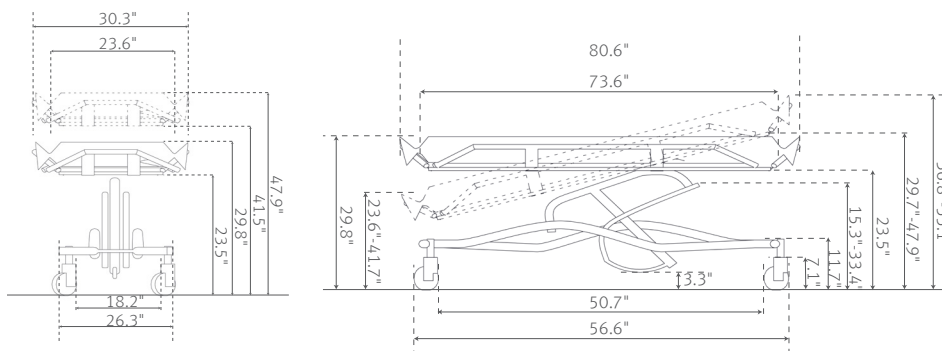

Consult the Technical manual for further specifications. All figures and measurements are for guidance only and may differ in actual situations. Ergolet reserves the right to changes without notice.

Product photos may include accessories. Consult your dealer.



date 21.02.2013 - ver. 7

Ergolet
 Taarnborgvej 12C
 4220 Korsøer
 Denmark
 tel. +45 70 27 37 20
 e-mail: ergolet@ergolet.dk

www.ergolet.com

